

<b>FREQUENCY STABILITY OVER:</b>	
OPERATING TEMP. RANGE :	see note 1
LONG TERM AGING 1ST YEAR:	< ±0.3 ppm *
10 YEARS:	< ±2.5 ppm *
SUPPLY VOLTAGE ± 0.15 V	
≤ 20 MHz	< ± 0.025 ppm
> 20 MHz	< ± 0.1 ppm
LOAD ±10%:	< ±0.01 ppm
<b>POWER SUPPLY</b>	
SUPPLY INPUT:	V <sub>cc</sub> = 3.3 V ± 0.15 V *
INPUT CURRENT :	< 110 mA @ +30 °C *
	< 170 mA @ -20 °C *
<b>FREQUENCY CONTROL RANGE</b>	
CONTROL VOLTAGE:	see note 2
FREQUENCY DEVIATION:	> ±2.5 ppm *
RESPONSE SLOPE:	positive
<b>OUTPUT</b>	
OUTPUT SIGNAL:	HC-MOS compatible
SYMMETRY:	40 (min.) / 60 (max.) % @ V <sub>cc</sub> / 2 *
RISE AND FALL TIME:	tr < 7ns tf < 7 ns *
LEVEL „0“ AND „1“:	< 0.4 V > V <sub>cc</sub> - 0.5 V
FAN OUT (LOAD):	10 LS
<b>ENVIRONMENT</b>	
OPERABLE TEMP. RANGE:	-40 to +85 °C
STORAGE TEMP. RANGE:	-65 to +125 °C
VIBRATION:	10 to 2000 Hz / 10 g
SHOCK:	2000 g, 0.3 ms, ½ sine
PACKAGE:	DIL 14, 4 pins, GND to case
PACKAGE HEIGHT:	8 mm (see packaging info)
<b>WARM-UP</b>	
ΔF/F:	within spec after 120s @ 30 °C *
CURRENT:	< 250 mA during 30s
<b>MISCELLANEOUS</b>	
SHORT TERM STABILITY:	< 1 E-10 0.1 s to 30 s Typical < 5 E-11 @ 1 s
PHASE NOISE (BW = 1Hz):	10 Hz: -100 dBc / Hz (typical, @ 10MHz in static conditions)
	100 Hz: -130 dBc / Hz
	1 KHz: -140 dBc / Hz
	10 KHz: -145 dBc / Hz

\* Customer's specification on request

<b>NOTE 1</b>	
TEMP. RANGE *	<b>SCOCXOWT-AR1, AV3</b> 0 to +60 °C
STABILITY *	±0.05 ppm (0.1 ppm peak to peak)
TEMP. RANGE *	<b>SCOCXOWT-BR1, BV3</b> -20 to +70 °C
STABILITY *	±0.075 ppm (0.15 ppm peak to peak)
TEMP. RANGE *	<b>SCOCXOWT-CR1, CV3</b> -40 to +85 °C
STABILITY *	±0.1 ppm (0.2 ppm peak to peak)

<b>NOTE 2</b>	
ADJUSTMENT WITH RESISTOR	<b>SCOCXOWT-AR1, BR1, CR1</b> 0 to 10 kΩ (connected to ground)
INPUT IMPEDANCE	> -4.7 kΩ
ADJUSTMENT WITH VOLTAGE	<b>SCOCXOWT-AV3, BV3, CV3</b> 0 to 3.3 V
INPUT IMPEDANCE	> 47 kΩ

<b>MARKING EXAMPLE</b>			
<b>Micro Crystal</b>		<b>Micro Crystal</b>	
SCOCXOWT-BV3		Type	Spec No.
20.000 MHz	09.25	Frequency	Date Code
○	12	○ (PIN 1)	Piece No.

<b>ORDERING INFORMATION EXAMPLE</b>			
S C O C X O W T - B V 3 20 MHz x x x			
Oscillator Type	SCOCXO = Low g sensitivity Oven Controlled Crystal Oscillator		N° of customer spec.
Oscillator Version	W = low power voltage 3.3V T = tight tolerance	Oscillator output frequency	
Temperature Range	A = 0 to +60 °C; +/-0.025ppm B = -20 to +70 °C; +/-0.05ppm C = -40 to +85 °C; +/-0.1ppm X = custom spec.	Frequency Adjustment	R1 = external resistor V3 = voltage 3.3V Y = custom spec.

<b>STANDARD FREQUENCIES (MHz)</b>					
10.0000	12.8000	16.0000	16.3840	19.4400	20.0000
26.0000	40.0000	50.0000	52.0000		

DATE:	October 2009	Revision No.: 1
-------	--------------	-----------------

In accordance with our policy of continuous development and improvement, we reserve the right to modify the design or the specifications of our products without prior notice.

Headquarters:	Micro Crystal AG Mühlestrasse 14 CH-2540 Grenchen Switzerland	Tel.	+41 32 655 82 82
		Fax	+41 32 655 80 90
		Internet	www.microcrystal.ch
		Email	sales@microcrystal.ch

**Application and Test Circuit:**

Adjustment with voltage

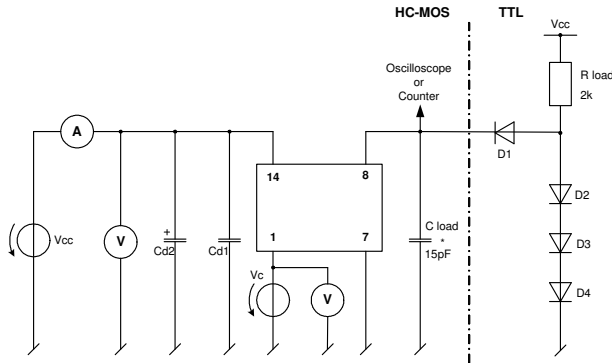

Adjustment with resistor

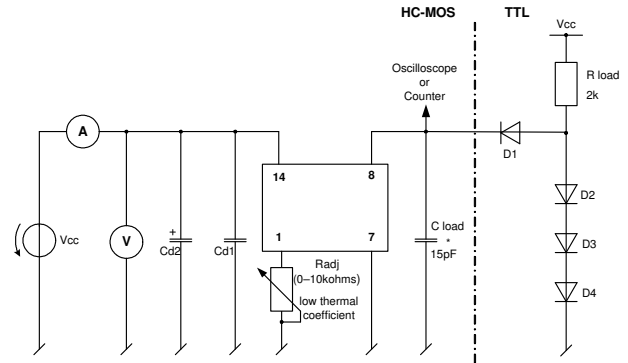

**Waveform Output:**

Waveshape TTL

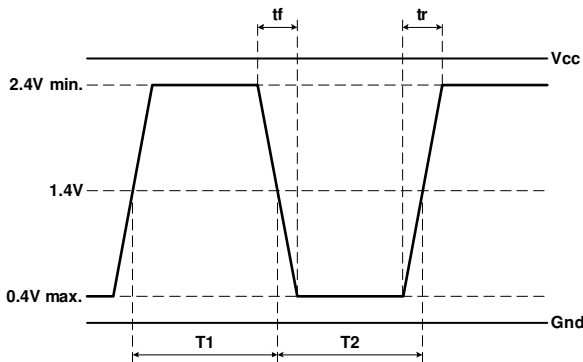

Waveshape HC-MOS

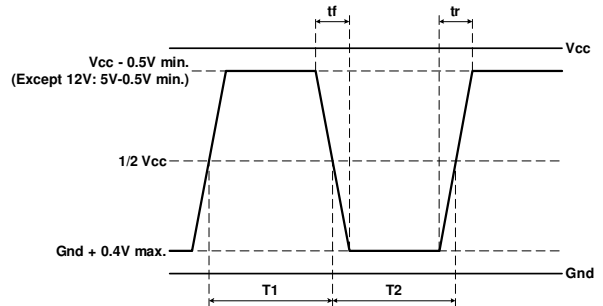

$$Duty\ Cycle = 100 \times \frac{T1}{T1 + T2} [\%]$$